

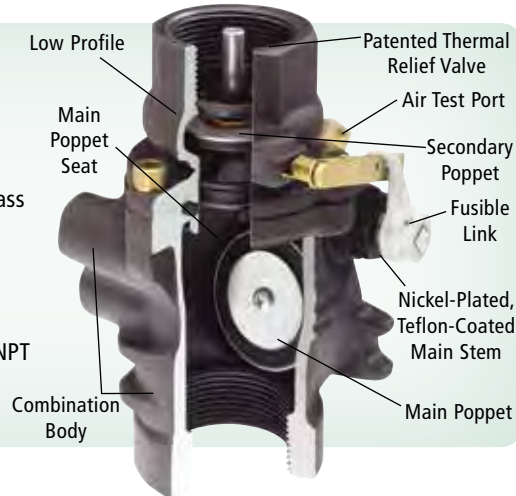

Materials

Top: Cast iron
Body: Cast iron
Disc: M-19
Carrier: Zinc-plated steel
Stem: Copper-nickel-chrome-plated brass
Poppet Spring: Stainless steel
Seal: M-19 O-Ring
Packing nut: Brass, Teflon®-coated
 Inlet and outlet thread: 1-1/2" (4 cm) NPT
 (British threads available)
 *With black Duragard® E-Coating



Features

- ◆ **High Flow Capacity** – the primary poppet is held out of the flow stream while the secondary poppet is held normally open to minimize head loss across the valve and to protect the poppet seals from damage and erosion. True 1-1/2" (4 cm) and 2" (5 cm) body sizes ensure maximum flow.
- ◆ **Fire Protection** – a fusible link trips the valve closed at 165° F to shut off fuel supply to the dispenser.
- ◆ **Main Poppet Seat Integral to the Top Assembly** – having the main poppet seat as an integral part of the valve top ensures a new, clean seating surface is installed each time the top is replaced. This design also ensures that the integrity of the seal between the valve top and bottom is verified during line testing and allows full inspection of the main poppet when the top is removed.
- ◆ **Duragard®-Coat Finish** – provides superior corrosion resistance.
- ◆ **Reliable Shut-off** – a stainless steel main spring, a teflon-coated brass packing nut and a copper/nickel/ chrome-plated brass stem are designed to prevent tar build-up and corrosion from interfering with poppet operation after long periods of normal service without activation.
- ◆ **Integral Test Port** – a 3/8" (9.5 mm) test port allows the piping system to be air-tested without breaking any piping connections.
- ◆ **Patented Thermal Relief Valve** – relieves excessive pressure over 25 psi caused by thermal expansion of fuel in the dispenser piping system in the event of fire (double-poppet models only).
- ◆ **Low-Profile Tops** – female and union-top double-poppet valves have a low-profile top to allow upgrading from OPW single-poppet valves without changing existing piping.
- ◆ **Multiple Mounting Options** – valves are boss-mounted to stabilizer bars in sumps and pans or mounted to bars embedded in the island with optional U-Bolt kits 10UBK-015 (not included). Versatile Combination Body (boss mount/ U-Bolt mount) models are available to accommodate most mounting applications with one valve style.
- ◆ **Underwriters Laboratories** –  listed for use with gasoline and 85% and 100% methanol. All OPW 10 Emergency Shut-Off Valves meet requirements of UL STANDARD 842.
- ◆ **Compatible with 85% ethanol (E85)**

10 Series Emergency Shut-Off Valves

OPW 10 Series Emergency Shut-off Valves are installed on fuel supply lines beneath dispensers at grade level to minimize hazards associated with collision or fire at the dispenser. If the dispenser is pulled over or dislodged by collision, the top of the valve breaks off at the integral shear groove, activating poppets and shutting off the flow of fuel. Single-poppet models shut off supply flow, while double-poppet models shut off supply as well as prevent release of fuel from the dispenser's internal piping. The base of the emergency valve is securely anchored to the concrete dispenser island through a stabilizer bar system within the dispenser sump or pan to ensure proper shearing action. The valve base is secured to the stabilizer bar using a three-point boss mount system or a U-Bolt Kit (not included) 10UBK-015 (1-1/2") and 10URK-0200 (2" sold separately). Valve inlet (bottom) connections are female pipe threads and outlet (top) connections are available with female threads, male threads or a union fitting. Other options include suction system models with a normally closed secondary poppet which maintains prime, and models with external threads on the inlet body which connect to secondary containment systems.

PA15 Offset Adaptor

The OPW PA15 Offset Adaptor is designed for adjusting misalignment of pipe in dispenser sumps and suction stubs. The PA15 has a low profile feature, and is designed for maximum flow.

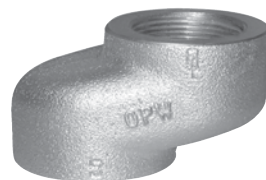

Materials

Ductile Iron
 Zinc Chromate

Ordering Specifications

Part #	Thread Size		Offset		Height		Width	
	in.	mm	in.	mm	in.	mm	in.	mm
PA15-10	1 1/2	38.1	1	25	2 1/4	57.2	3 5/8	92.1
PA15-15	1 1/2	38.1	1 1/2	38.1	2 1/4	57.2	4 1/8	104.8
PA15-20	1 1/2	38.1	2	51	2 1/4	57.2	4 5/8	117.5

OPW 10 Series Emergency Shut-Off Valves

Ordering Specifications

Female Threaded Top (Outlet) Connection Valves

Model #	Body Size		Connection Threads	Poppet Configuration	Application	Replacement Top
	in.	cm				
10BF-5725	1½	4	NPT	Single	Pressure	10RFT-5750
10BFP-5726	1½	4	NPT	Double	Pressure	10FTP-5701
10RF-2001	2	5	NPT	Single	Pressure	10RFT-5742
10RFP-2002	2	5	NPT	Double	Pressure	10RFTP-5752

Male Threaded-Top (Outlet) Connection Valves

Model #	Body Size		Connection Threads	Poppet Configuration	Application	Replacement Top
	in.	kg				
10BM-5825	1½	4	NPT	Single	Pressure	10RMT-5850
10BHMP-5830	1½	4	NPT	Double	Pressure	10RMTP-5851
10SBHMP-5830	1½	4	NPT	Double	Suction	10SHMTP-5811
10RM-2003	2	5	NPT	Single	Pressure	10RMT-5842
10RMP-2004	2	5	NPT	Double	Pressure	10RMTP-5852

Union-Top (Outlet) Connection Valves

Model #	Body Size		Connection Threads	Poppet Configuration	Application	Replacement Top
	in.	kg				
10BU-5925	1½	4	NPT	Single	Pressure	10RUTC-5975
10BUP-5926	1½	4	NPT	Double	Pressure	10UTCP-5901
10SBUP-5926	1½	4	NPT	Double	Suction	10SUTCP-5911
10RU-2005	2	5	NPT	Single	Pressure	10RUTC-5962
10RUP-2006	2	5	NPT	Double	Pressure	10RUTCP-5972

NOTE: All BSPP Thread Shear Valves must be ordered through OPW's Europe or Asia office.

IMPORTANT NOTICE:

When mounting the OPW 10 Series Emergency Shut-off Valves, the anchoring system employed must withstand a force greater than 650 ft. pounds per valve. NFPA Code 30A, Automotive and Marine Service Station Code, requires that the automatic closing feature of emergency shut-off valves be checked at least once per year by manually tripping the hold-open linkage. OPW recommends the use of Flexworks Stabilizer Bar Support System for proper mounting of 10 Series Valves.

NOTICE:

As per NFPA 30A, electrical supply to the submersible pump must always be disconnected before servicing meters, dispensers or emergency shut-off valves.

Replacement Valve Tops

Model #	Body Size		Connection Threads	Poppet Configuration	Application	Top Connection	Profile
	in.	cm					
10RFT-5750	1½	4	NPT	Single	Pressure	Female	
10RFTP-5751	1½	4	NPT	Double	Pressure	Female	
10FTP-5701	1½	4	NPT	Double	Pressure	Female	Low Profile
10RMT-5850	1½	4	NPT	Single	Pressure	Male	
10RMTP-5851	1½	4	NPT	Double	Pressure	Male	
10SHMTP-5811	1½	4	NPT	Double	Suction	Male	
10RUTC-5975	1½	4	NPT	Single	Pressure	Complete Union	
10UTCP-5901	1½	4	NPT	Double	Pressure	Complete Union	Low Profile
10RFT-5742	2	4	NPT	Single	Pressure	Female	
10RFTP-5752	2	5	NPT	Double	Pressure	Female	
10RMT-5842	2	5	NPT	Single	Pressure	Male	
10RMTP-5852	2	5	NPT	Double	Pressure	Male	
10RUTC-5962	2	5	NPT	Single	Pressure	Complete Union	
10RUTCP-5972	2	5	NPT	Double	Pressure	Complete Union	

1½" Dimensions

	10BF		10BFP 10SBFP		10BM		10BHMP 10SBHMP		10BU		10BUP 10SBUP	
	in.	mm	in.	mm	in.	mm	in.	mm	in.	mm	in.	mm
A	6 ²¹ / ₆₄	161	6 ²¹ / ₆₄	161	6 ¹³ / ₁₆	173	7 ¹¹ / ₁₆	195	7 ¹ / ₄	184	7 ¹ / ₄	184
B	2 ³ / ₄	70	2 ³ / ₄	70	2 ³ / ₄	70	2 ³ / ₄	70	2 ³ / ₄	70	2 ³ / ₄	70
C	2 ¹¹ / ₁₆	69	2 ¹¹ / ₁₆	69	2 ¹¹ / ₁₆	69	2 ¹¹ / ₁₆	69	2 ¹¹ / ₁₆	69	2 ¹¹ / ₁₆	69
D	1 ³ / ₄	44	1 ³ / ₄	44	2 ¹ / ₄	57	3 ¹ / ₈	79	2 ¹¹ / ₁₆	69	2 ¹¹ / ₁₆	69

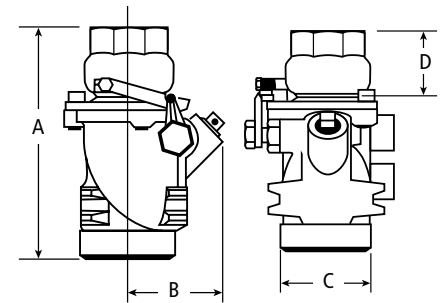

2" Dimensions

	10RF 10RFS		10RM 10RMS		10RU 10RUS		10RFP 10RFSP		10RMP 10RMSP		10RUP 10RUSP	
	in.	mm	in.	mm	in.	mm	in.	mm	in.	mm	in.	mm
A	8 ³ / ₈	213	9 ²⁷ / ₃₂	250	9 ¹³ / ₃₂	239	8 ³ / ₈	213	9 ²⁷ / ₃₂	250	9 ¹³ / ₃₂	239
B	3 ⁷ / ₆₄	79	3 ⁷ / ₆₄	79	3 ⁷ / ₆₄	79	3 ⁷ / ₆₄	79	3 ⁷ / ₆₄	79	3 ⁷ / ₆₄	79
C	3 ¹ / ₄	83	3 ¹ / ₄	83	3 ¹ / ₄	83	3 ¹ / ₄	83	3 ¹ / ₄	83	3 ¹ / ₄	83
D	3 ¹ / ₁₆	78	4 ⁹ / ₁₆	116	3 ⁷ / ₈	98	3 ¹ / ₁₆	78	4 ⁹ / ₁₆	116	3 ⁷ / ₈	98

Other Replacement Parts

Part #	Description
202950	Tetra Seal
H07659M	Link Spring
H07643RB	Link Retaining Screw
H04788M	Hold-Open Link (Brass)
H05361	Safety Hub S/A-Fusable Link
10UBK-015	U-Bolt Kit for 1½"
10URK-020	U-Bolt Kit for 2"